

BERGMANN II C 815 s

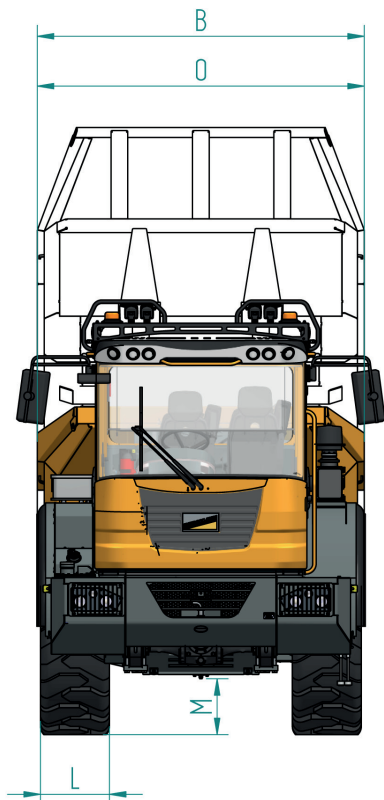

Rear tip dumper

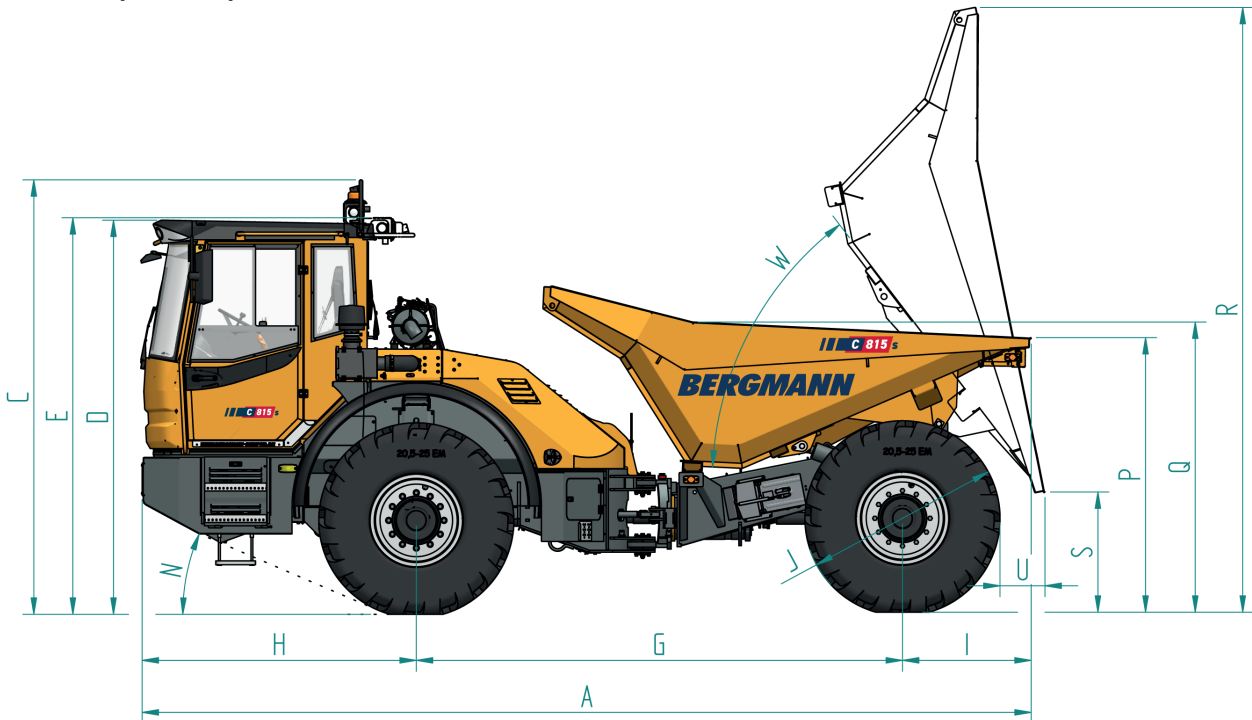

Dimensions

| | | |
|---|----------|----------|
| A | 6,834 mm | 22.42 ft |
| B | 2,505 mm | 8.22 ft |
| C | 3,338 mm | 10.95 ft |
| D | 3,028 mm | 9.93 ft |
| E | 3,047 mm | 10.00 ft |
| G | 3,737 mm | 12.26 ft |
| H | 2,108 mm | 6.92 ft |
| I | 989 mm | 3.24 ft |
| J | 1,500 mm | 4.92 ft |
| L | 529 mm | 1.74 ft |
| M | 429 mm | 1.41 ft |
| O | 2,505 mm | 8.22 ft |
| P | 2,110 mm | 6.92 ft |
| Q | 2,230 mm | 7.32 ft |
| R | 4,647 mm | 15.25 ft |
| S | 952 mm | 3.12 ft |
| W | | 76° |

Weight

| | | |
|--------------|-----------|-----------|
| Empty weight | 9,080 kg | 20,017 lb |
| Payload | 12,000 kg | 26,455 lb |

Bucket capacity

| | | |
|--------|------------------|----------------------|
| Struck | 5 m ³ | 6.5 yd ³ |
| Heaped | 8 m ³ | 10.5 yd ³ |

All illustrations, dimensions and weights do not necessarily correspond to the standard equipment and are non-binding with regard to tolerance deviations on component level. We reserve the right to make technical changes.



BERGMANN II C 815 s



Three-way tip dumper

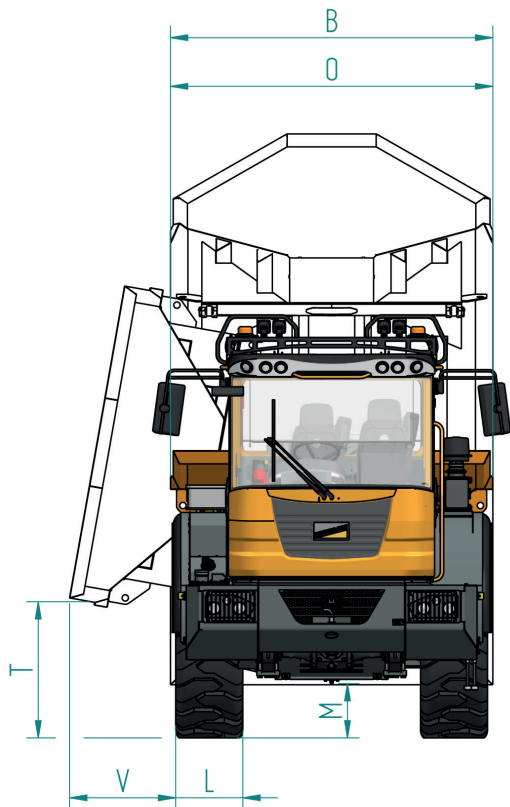
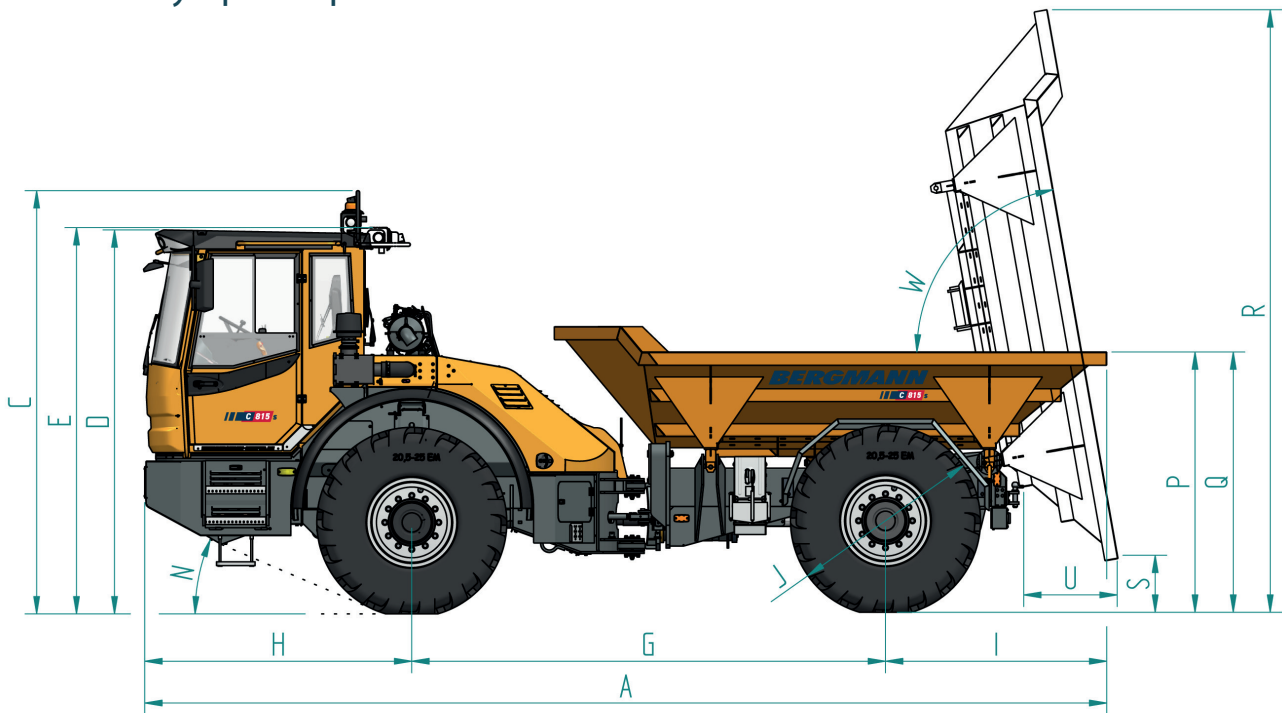

Dimensions

| | | |
|---|----------|----------|
| A | 7,593 mm | 24.91 ft |
| B | 2,541 mm | 8.34 ft |
| C | 3,338 mm | 10.95 ft |
| D | 3,028 mm | 9.93 ft |
| E | 3,047 mm | 10.00 ft |
| G | 3,739 mm | 12.27 ft |
| H | 2,107 mm | 6.91 ft |
| I | 1,746 mm | 5.73 ft |
| J | 1,500 mm | 4.92 ft |
| L | 529 mm | 1.74 ft |
| M | 429 mm | 1.41 ft |
| N | | 23° |
| O | 2,541 mm | 8.34 ft |
| P | 2,052 mm | 6.73 ft |
| Q | 2,052 mm | 6.73 ft |
| R | 4,752 mm | 15.59 ft |
| S | 449 mm | 1.47 ft |
| T | 1,075 mm | 3.53 ft |
| U | 738 mm | 2.42 ft |
| V | 836 mm | 2.74 ft |
| W | | 80° |

Weight

| | | |
|--------------|-----------|-----------|
| Empty weight | 10,020 kg | 22,090 lb |
| Payload | 12,000 kg | 26,455 lb |

Bucket capacity

| | | |
|--------|--------------------|----------------------|
| Struck | 4,2 m ³ | 5.5 yd ³ |
| Heaped | 8 m ³ | 10.5 yd ³ |

All illustrations, dimensions and weights do not necessarily correspond to the standard equipment and are non-binding with regard to tolerance deviations on component level. We reserve the right to make technical changes.



BERGMANN II C 815 s



Swivel-tip dumper

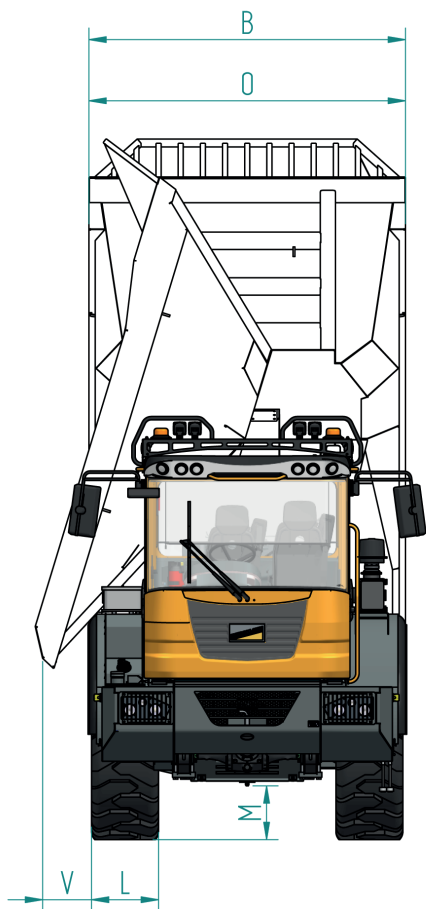
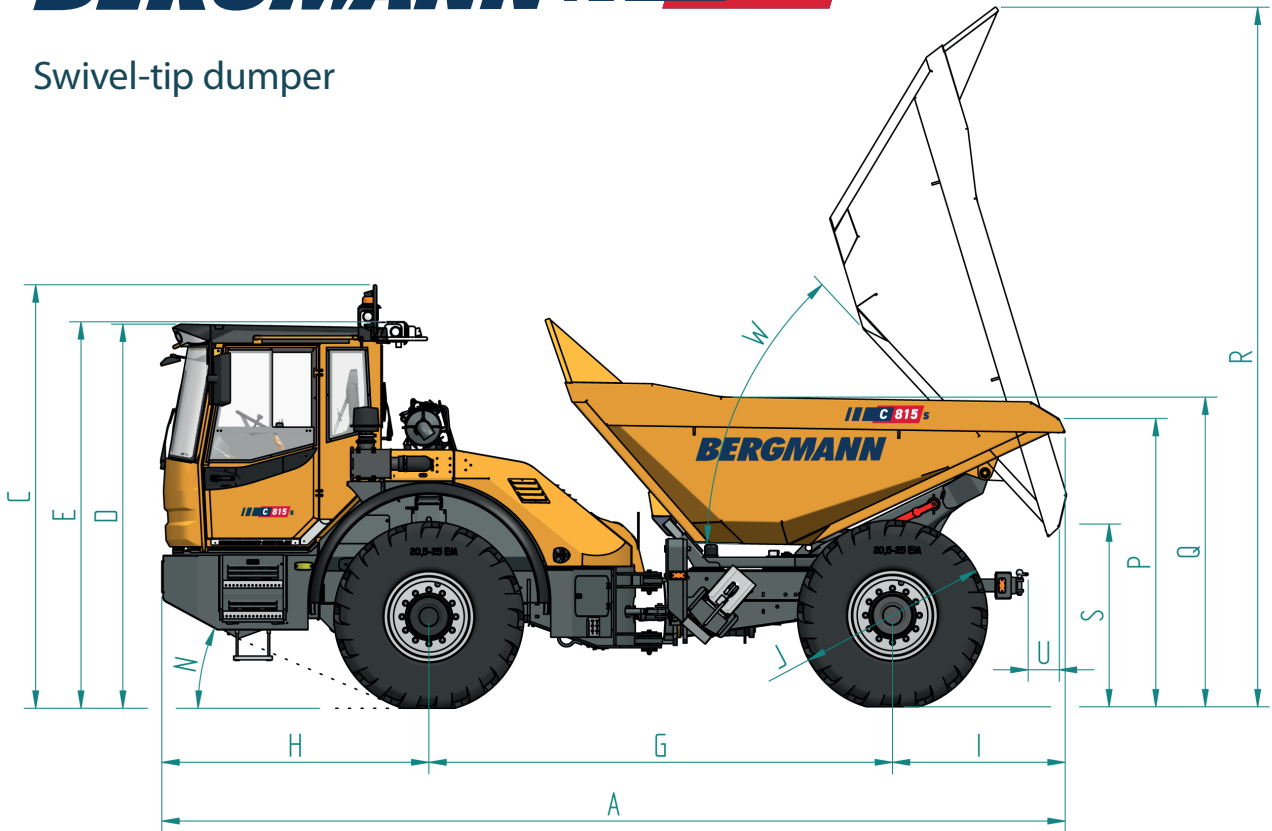

Dimensions

| | | |
|---|----------|----------|
| A | 7,129 mm | 23.39 ft |
| B | 2,500 mm | 8.20 ft |
| C | 3,338 mm | 10.95 ft |
| D | 3,028 mm | 9.93 ft |
| E | 3,047 mm | 10.00 ft |
| G | 3,659 mm | 12.00 ft |
| H | 2,107 mm | 6.91 ft |
| I | 1,362 mm | 4.47 ft |
| J | 1,500 mm | 4.92 ft |
| L | 529 mm | 1.74 ft |
| M | 424 mm | 1.39 ft |
| N | | 23° |
| O | 2,500 mm | 8.20 ft |
| P | 2,273 mm | 7.46 ft |
| Q | 2,442 mm | 8.01 ft |
| R | 5,516 mm | 18.10ft |
| S | 1,441 mm | 4.73 ft |
| U | 246 mm | 0.81 ft |
| V | 386 mm | 0.99 ft |
| W | | 46° |

Weight

| | | |
|--------------|-----------|-----------|
| Empty weight | 11,140 kg | 20,017 lb |
| Payload | 12,000 kg | 26,455 lb |

Bucket capacity

| | | |
|--------|--------------------|----------------------|
| Struck | 6.3 m ³ | 8.5 yd ³ |
| Heaped | 8 m ³ | 10.5 yd ³ |

All illustrations, dimensions and weights do not necessarily correspond to the standard equipment and are non-binding with regard to tolerance deviations on component level. We reserve the right to make technical changes.

Technical data

Highlights

- High stability thanks to oscillating axle
- Swivelling operator's stand
- Electro hydraulic spring type cylinder park brake
- Compact dimensions and low weight

Engine

| | |
|---|-----------|
| 4 cylinder Cummins diesel engine – water-cooled | |
| Power | 119 kW |
| Rotational speed | 2,200 rpm |
| Emission standard | Stage 5 |

Transmission

Load-depending shift – manually shiftable by hand and automatically, self-adjusting optimisation of traction force and speed, speed control stepless forward and backwards, ZF-Ergo-Power transmission

| | | |
|-------------|------------|--------------|
| 1. gear f/b | 6/6 km/h | 3.7/3.7 mph |
| 2. gear f/b | 9/15 km/h | 5.6/9.3 mph |
| 3. gear f/b | 14/33 km/h | 8.7/20.5 mph |
| 4. gear f | 21 km/h | 13.0 mph |
| 5. gear f | 32 km/h | 19.9 mph |
| 6. gear f | 40 km/h | 24.9 mph |

Steering

Hydraulic articulated steering via priority valve; articulated joint: 37° left and right

Axles/Brakes

- Front axle with leaf spring suspension, rear axle rigid
- Maintenance-free oil-bath multi-disc brake in the wheel hubs with self-locking differential with a locking value of 45 %
- Hydraulically applicated spring-type cylinder locking brake acting over articulated shaft on front and rear axle

Standard tyres

All tyres 20.5-25 Double Coin
(more tyre options on request)

Tank capacity

| | |
|---------------|-------|
| Fuel | 190 L |
| Hydraulic oil | 64 L |

Electrics

- 24 V electric system with main switch
- Fault detection mode
- Control lamps for engine oil, park brake, driving display, battery charging control and hydraulic filter
- Display for drive position

Standard equipment

- Comfortable driver's cab with air-suspended driver's seat
- Swivelling operator's stand
- Lighting system in accordance with German traffic regulations
- Bucket from wear-resistant fine-grain steel
- Beacon light, cigarette lighter
- Sun blind for front windscreen
- Device for radio, loudspeaker and antenna
- CE conformity declaration
- Manual/Spare parts list